



关于我们

ABOUT COMPANY

Shenzhen HengTongXing Techonology Co.,Ltd has already specialized in the production and customization of non-standard molds accessories for over 20+years in Shenzhen, China.Our main products include hardware,plastic mold accessories,machined parts,test fixtures,and a series of O E M non-standard parts processed according to drawings.All of these molds accessories are widely used for high-precision hardware,plastic,cars,communications,electronics,machines,and die-casting,etc.All our products are passed five strict quality inspections by Q A to ensure that the qualification rate reaches 98% when shipment.

We have professional engineer support,high efficiency sales team and competitive price superiority,all of which attract customers from all over the world.We export to over 40 countries,includingUSA,Iraq,Russia,Israel,Cameroon,Malaysia,Angola,Kazakhstan,Qatar,Morocco,Australia,Algeria,and Vietnam,etc.After more than eighteen years' development,we have achieved great progress.We are equipped with four workshops,over 60processing equipmentimported from Japan,and over 20 sets of special testing equipment including 3-dimensional high-end inspection instruments and full CNC testing so that our product can guarantee one hundred thousand punches without fracture,0 die change,which can increase output and reduce labor.

Our R&D department provide the strong technical support and enable us to receive all kinds of O E M, O D M projects. We can produce at least 10,000pcs molds per day.

This factory is HTX in China.We are a reliable supplier of non-standard molds accessories with 20+years official warranty.Our shared belief is that HTX could be the best mould factory in the world.We sincerely hope to cooperate with you!

深圳市恒通兴科技有限公司是位于中国深圳，20多年专注非标模具配件的生产与订制！我们主营五金、塑胶模具配件、机加工零件、检测治具夹具、及一系列按图定制的OEM非标件。这些配件可以广泛用于高精度五金、塑胶、汽车、通讯、电子，机械设备，压铸等。我们所有加工出来的产品都通过了5道品检部严格检测，确保出货品质合格率达98%以上。

我们通过专业的工程师队伍，高效的销售团队以及具有优势的价格吸引了来自于全球各地的客户。我们出口国家超过了40个，其中包括美国、伊拉克、俄罗斯、以色列、喀麦隆、马来西亚、安哥拉、哈萨克斯坦、卡塔尔、摩洛哥、澳大利亚、阿尔及利亚、越南。经过十几年的发展，我们取得了很大的进步，配有4个工厂，60多台日本进口加工设备，包括3次元高端检验仪器在内20多种检测设备，以及全程数控，所以我们的产品可以保证十万冲次不断裂，0换模，增加产量，减少人工。我们的工程部门提供强有力的技术支持，使我们能够接受各种非标件定制。我们可以在一天加工出10,000件非标配件。

我们共同的信念是做中国乃至全世界最好的模具配件。

我们是拥有20多年官方授权的可靠非标模具配件供应商。我们期待与您的合作！



TRP



SRP



A-TRP

注
NOTE

以上只是部分型号，我们可以根据客户的需求进行量身定制。
Note: the above is only part of the model, We could customized according to customer's requirements.

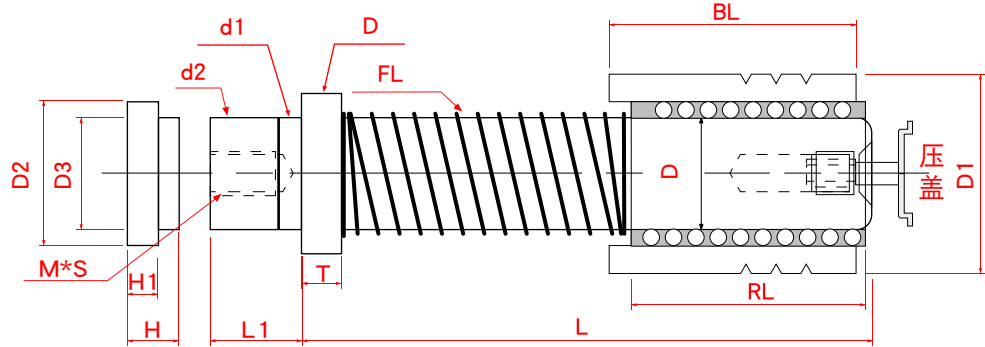

d	d1	d2	D	T	D3	D2	H	H1	L1	M*S	D1	BL	
20	+0 -0.006	+0 -0.005	-0.03 -0.05	30	5	19	28	12	6	15	M8*20	37	60-70
22				32	8	21	30					16	
25				35	14	7	18	45	70-100				
28				38				20		50			
32				44	16	8	27	55	80-120				
36				48				35		44		58	
38				50	12	12	27	64					
45				60				44		53		74	
50				66	15	15	9	83	M12*20				
60				76				49		58		95	
							18	9	38				

Catalog No.		L										②LBB		RL		
Type	D											Type	BL	RL		
PBSH	20	80	90	100	110	120	130	140	150	160	170	180	200	L (LBB)	50	50
PMSH	22	80	90	100	110	120	50	50								
PKSH		60	60	60	60											
GBSH	25	80	90	100	110	120	130	60	75							
GMSH		100	110	120	130	140	150	160	60	60						
GKSH	32	120	130	140	150	160	80	75								
PB		80	75													
PM	38	140	150	160	170	180	100	90								
PK		80	75													
GB	45	140	150	160	170	180	100	90								
BM		120	110													
GK	50	160	170	180	200	100	90									
		120	110													
	60	160	170	180	200	100	90									
		120	110													

注
NOTE

以上只是部分型号，我们可以根据客户的需求进行量身定制。

Note: the above is only part of the model, We could customized according to customer's requirements.

高刚性钢球导柱组件 High-rigidity ball guide post sets			钢球导柱组件 Ball guide post sets		
-无挡块- No stopper PBSH (QBSH)	-可动挡块- Mavable stopper RMSH (QMSH)	-固定挡块- Fixed stopper PKSH (QKSH)	-无挡块- No stopper PB (QB)	-可动挡块- Mavable stopper PM (QM)	-固定挡块- Fixed stopper PK (QK)
<p>①MSP(P. 929)</p>		<p>②BSPM (P. 929) ⑤STM (P. 937)</p>		<p>①BSPK (P. 931) ⑥STK (P. 937)</p>	
<p>③MBSH (P. 936) MBS (P. 936)</p>	<p>③MBJH (P. 936) MBJ (P. 936)</p>	<p>④SWPL (P. 937) SWP (P. 937)</p>	<p>②LBB (P. 933)</p>		

注
NOTE

以上只是部分型号，我们可以根据客户的需求进行量身定制。

Note: the above is only part of the model, We could customized according to customer's requirements.

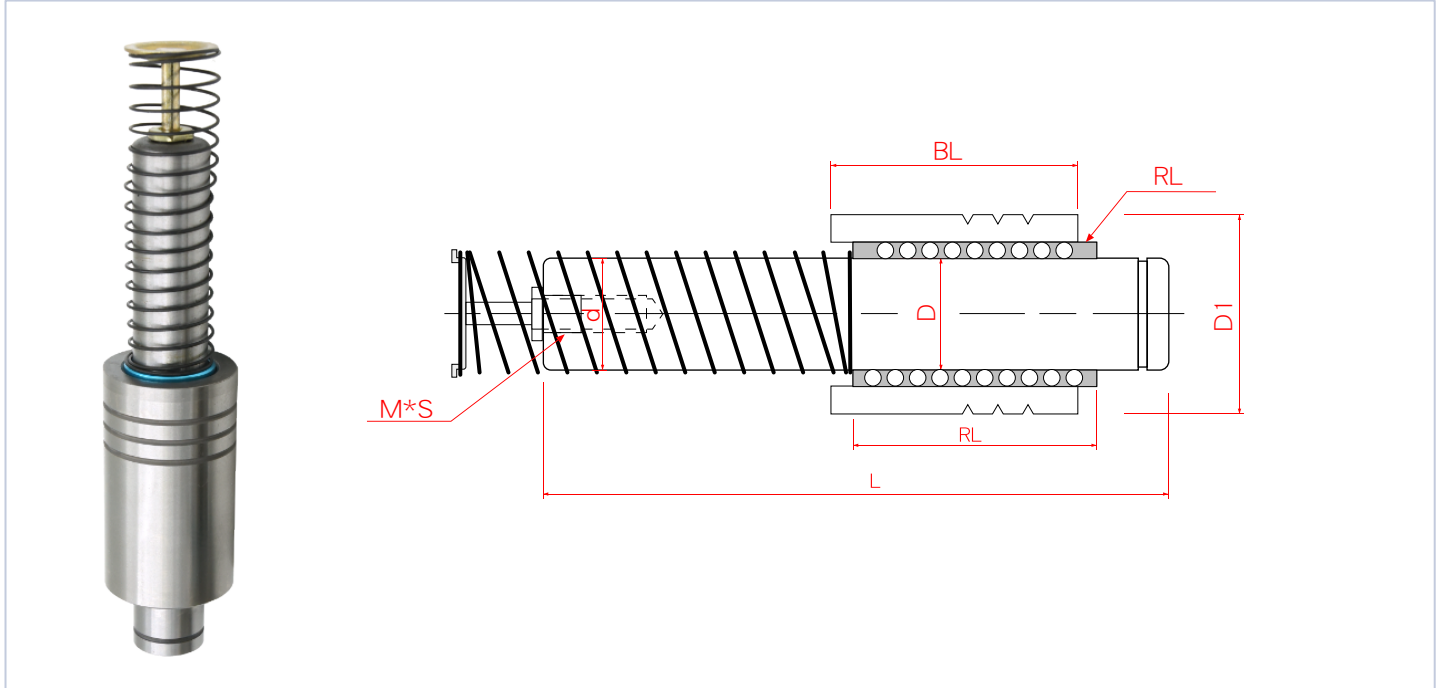





D	d	M*S	D1	RL	BL
20	+0.020	M6*15	37	50	50
22			40	50	50
25			44	60	60
28	+0.025	M8*20	48	60	75
32			54	60	60
38			63	80	75
45			74	100	75
50			78	100	90
60	+0.030	M12*20	88	100	90
				100	110
				120	90
				120	110

Catalog No.		L	②LBB	
Type	D		Type	RL
PBSH	20	100 110 120 130 140 150 160 170 180	L (LBB)	50
PMSH	22	120 130 140 150 160 170 180		50
PKSH				60
GBSH	25	120 130 140 150 160 170 180		60
GMSH	28	140 150 160 170 180 200		60
GKSH				60
PB	32	160 170 180 200 220 240		60
PM	38	180 200 220 240 260		80
PK				75
GB	45	180 200 220 240 260		75
BM	50	200 220 240 260		90
GK				90
	60	200 220 240 260		100
				110
				120
				120

注
NOTE

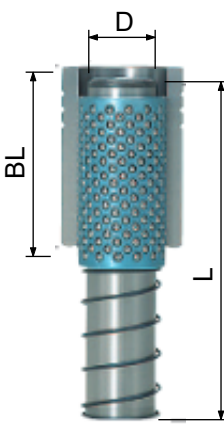
以上只是部分型号，我们可以根据客户的需求进行量身定制。

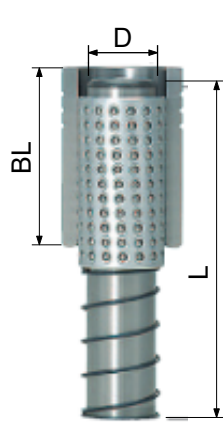
Note: the above is only part of the model, We could customized according to customer's requirements.

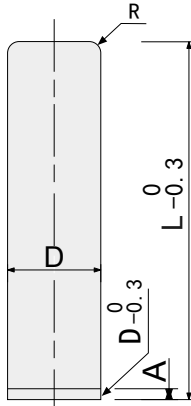
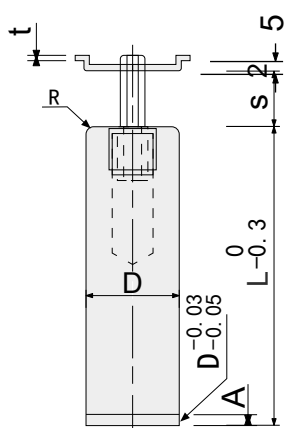
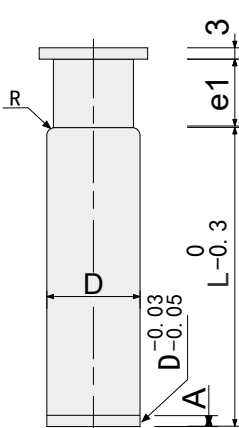
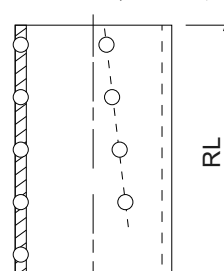
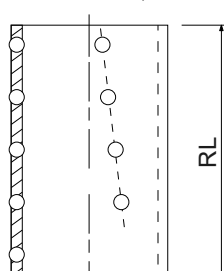
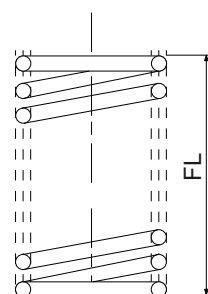
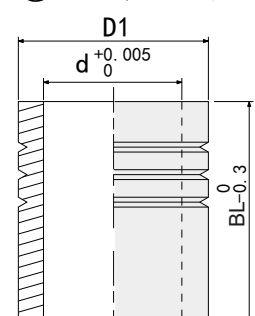
高刚性钢球导柱组件 High-rigidity ball guide post sets			钢球导柱组件 Ball guide post sets		
-无挡块- No stopper PBSH (GBSH)	-可动挡块- Mavable stopper PMSH (GMSH)	-固定挡块- Fixed stopper PKSH (GKSH)	-无挡块- No stopper PB (GB)	-可动挡块- Mavable stopper PM (GM)	-固定挡块- Fixed stopper PK (GK)
					
①MSP(P. 929)		②BSPM (P. 929) ⑤STM (P. 937)		①BSPK (P. 931) ⑥STK (P. 937)	
					
③MBSH (P. 936) MBS (P. 936)		③MBJH (P. 936) MBJ (P. 936)		④SWP (P. 937)	
					
				②LBB (P. 933)	
					

注
NOTE

以上只是部分型号，我们可以根据客户的需求进行量身定制。

Note: the above is only part of the model, We could customized according to customer's requirements.

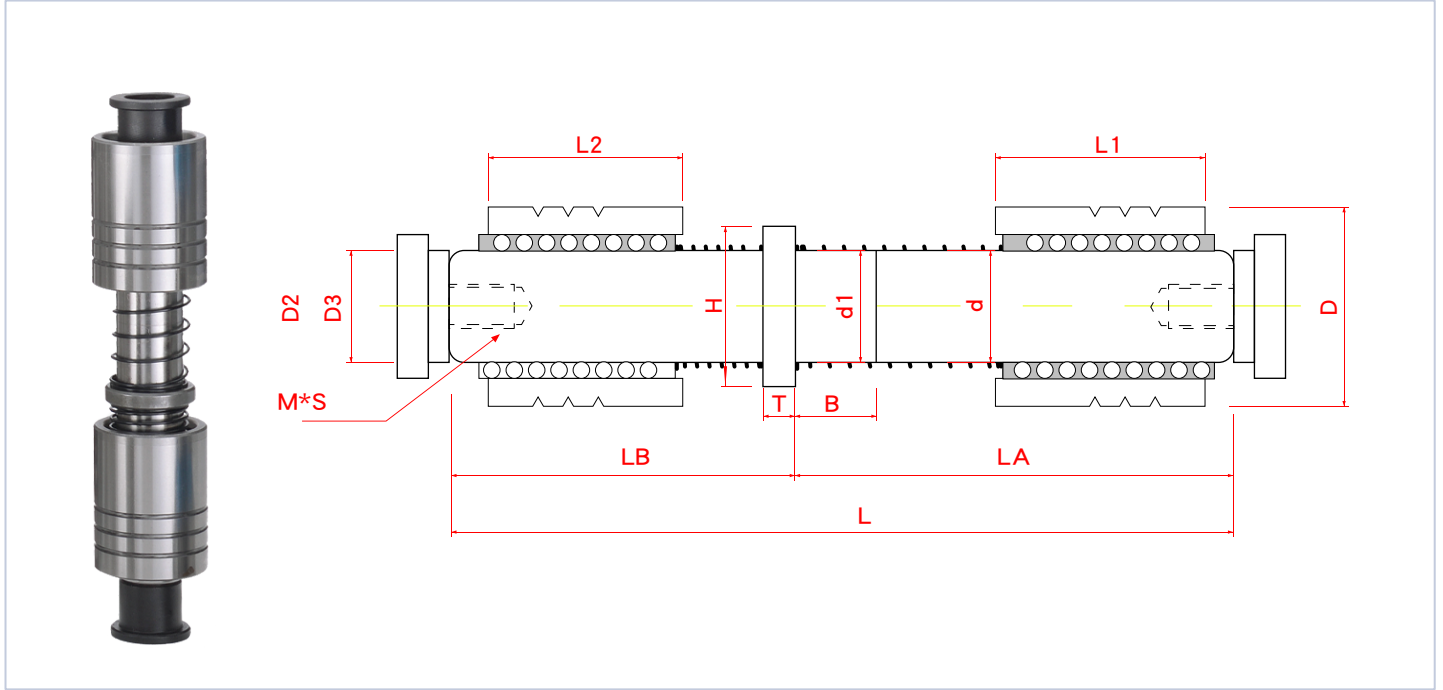

d			d1	H	B	D	M*S
16	-0.010 -0.015	16	+0.010 +0.015	23	20	28	M6*20
18		18		25		30	M8*20
20		20		27		34	M8*20

L	LA	LB	T	L1	L2
120	65	55	5	35	30
130	7	60		40	35
140	80	60		40	35

注
NOTE

以上只是部分型号，我们可以根据客户的需求进行量身定制。

Note: the above is only part of the model, We could customized according to customer's requirements.

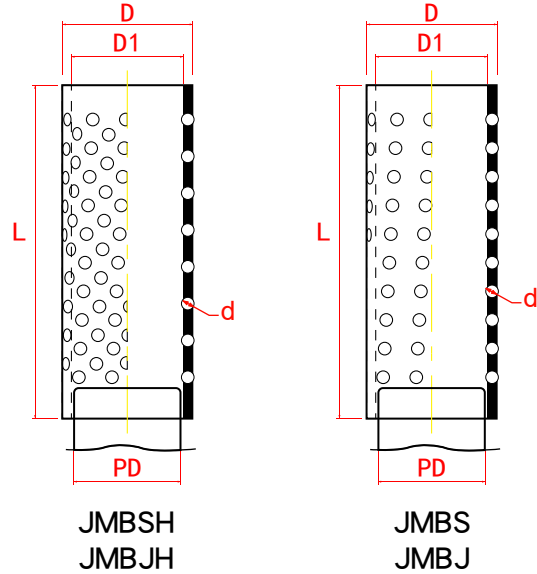

Code	PD	L	D	D1	d	MBSH	MBJH	MBS	MBJ	比率Ratio	
JMBSH (高刚性铝合金) JMBJH (高刚性树脂) JMBS (合金) JMBJ	20	50	25.5	20.5	3	165		96		1.72	
	22	50	27.5	22.5		180		112		1.61	
		60				228		140		1.63	
	25	60	30.5	25.5		266		160		1.66	
		75				350		208		1.68	
	28	60	35.5	28.5		4	204		112		1.82
		75			252			154		1.64	
	32	75	39.5	32.5	294			176		1.67	
		90			350			208		1.68	
	38	75	47.5	38.5	5		238		144		1.65
		90					280		176		1.67
	45	90	54.5	45.5		320		198		1.70	
		110				400		234		1.71	
	50	90	59.5	50.5		360		220		1.72	
		110				450		260		1.73	
	60	90	69.5	60.5		400		242		1.74	
110		500					286		1.75		

注
NOTE

以上只是部分型号，我们可以根据客户的需求进行量身定制。

Note: the above is only part of the model, We could customized according to customer's requirements.