



关于我们

ABOUT COMPANY

Shenzhen HengTongXing Techonology Co.,Ltd has already specialized in the production and customization of non-standard molds accessories for over 20+years in Shenzhen, China.Our main products include hardware,plastic mold accessories,machined parts,test fixtures,and a series of O E M non-standard parts processed according to drawings.All of these molds accessories are widely used for high-precision hardware,plastic,cars,communications,electronics,machines,and die-casting,etc.All our products are passed five strict quality inspections by Q A to ensure that the qualification rate reaches 98% when shipment.

We have professional engineer support,high efficiency sales team and competitive price superiority,all of which attract customers from all over the world.We export to over 40 countries,includingUSA,Iraq,Russia,Israel,Cameroon,Malaysia,Angola,Kazakhstan,Qatar,Morocco,Australia,Algeria,and Vietnam,etc.After more than eighteen years' development,we have achieved great progress.We are equipped with four workshops,over 60processing equipmentimported from Japan,and over 20 sets of special testing equipment including 3-dimensional high-end inspection instruments and full CNC testing so that our product can guarantee one hundred thousand punches without fracture,0 die change,which can increase output and reduce labor.

Our R&D department provide the strong technical support and enable us to receive all kinds of O E M, O D M projects. We can produce at least 10,000pcs molds per day.

This factory is HTX in China.We are a reliable supplier of non-standard molds accessories with 20+years official warranty.Our shared belief is that HTX could be the best mould factory in the world.We sincerely hope to cooperate with you!

深圳市恒通兴科技有限公司是位于中国深圳，20多年专注非标模具配件的生产与订制！我们主营五金、塑胶模具配件、机加工零件、检测治具夹具、及一系列按图定制的OEM非标件。这些配件可以广泛用于高精度五金、塑胶、汽车、通讯、电子，机械设备，压铸等。我们所有加工出来的产品都通过了5道品检部严格检测，确保出货品质合格率达98%以上。

我们通过专业的工程师队伍，高效的销售团队以及具有优势的价格吸引了来自于全球各地的客户。我们出口国家超过了40个，其中包括美国、伊拉克、俄罗斯、以色列、喀麦隆、马来西亚、安哥拉、哈萨克斯坦、卡塔尔、摩洛哥、澳大利亚、阿尔及利亚、越南。经过十几年的发展，我们取得了很大的进步，配有4个工厂，60多台日本进口加工设备，包括3次元高端检验仪器在内20多种检测设备，以及全程数控，所以我们的产品可以保证十万冲次不断裂，0换模，增加产量，减少人工。我们的工程部门提供强有力的技术支持，使我们能够接受各种非标件定制。我们可以在一天加工出10,000件非标配件。

我们共同的信念是做中国乃至全世界最好的模具配件。

我们是拥有20多年官方授权的可靠非标模具配件供应商。我们期待与您的合作！



注
NOTE

以上只是部分型号，我们可以根据客户的需求进行量身定制。
Note: the above is only part of the model, We could customized according to customer's requirements.

BGA

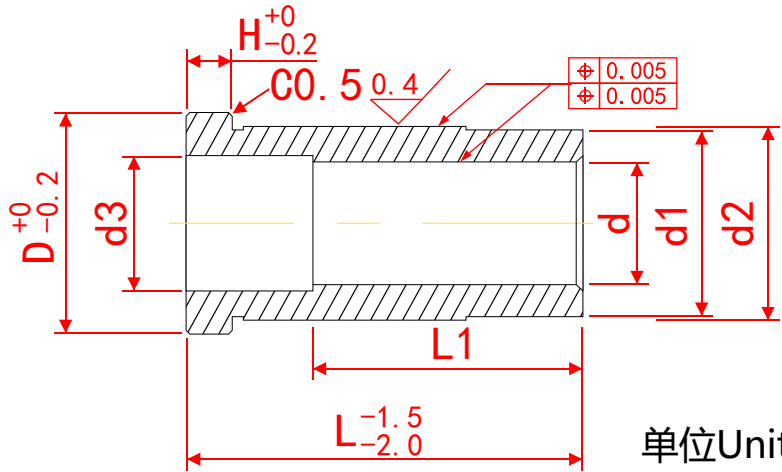

单位Unit:mm

D	d		L1	d1		d3	H	u
25	12	+0.018	2xd	20	+0.02	13	6	4
30	16	+0.008		25	+0.01	17		
35	20	+0.020 +0.010		30	+0.025 +0.015	21	8	6
40	25			35		26		
47	30			42		31		
53	35	+0.025 +0.015		48	+0.030 +0.018	36	10	8
60	40			55		41		
66	45			60		46		
76	50			70		51	12	
86	60	+0.035 +0.020		80	+0.035 +0.020	61	15	12
96	70			90		71		
110	80			105		81		
120	90			115		91		
135	100			130		101		

注
NOTE

以上只是部分型号，我们可以根据客户的需求进行量身定制。

Note: the above is only part of the model, We could customized according to customer's requirements.

EGB

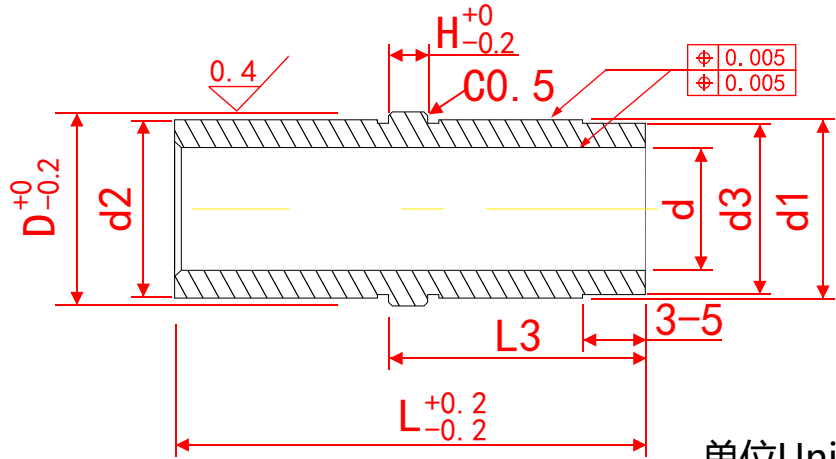

单位Unit:mm

L	26	28	33	38	43	48	53	58	63	68	73	78
L3	14		19		24		29		34		39	

D	d		d2	d1		H	d3
25	12	+0.02	-0.02 -0.03	20	+0.01	6	-0.03 -0.05
30	16	+0.03		25	+0.02		
35	20	+0.03 +0.04		30	+0.015 +0.025	8	
40	25			35			
47	30			42			
53	35	+0.03 +0.04		48	+0.02 +0.03	10	
60	40			55			
66	45			60			
76	50	+0.03 +0.04		70		12	
86	60			80		15	

注
NOTE

以上只是部分型号，我们可以根据客户的需求进行量身定制。

Note: the above is only part of the model, We could customized according to customer's requirements.

BGB

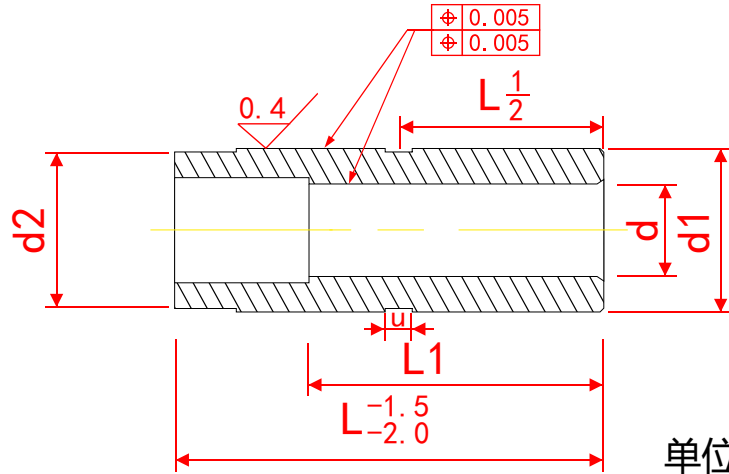

单位Unit:mm

L	20	25	30	35	40	50	60	70	80	90	100
---	----	----	----	----	----	----	----	----	----	----	-----

D	d		d1		d2	d3	L1	u
25	12	+0.018	20	+0.020	-0.020 -0.040	13	2xd	4
30	16	+0.008	25	+0.010		17		
35	20	+0.020 +0.010	30	+0.025 +0.015		21		6
40	25		35			26		
47	30		42			31		
53	35	+0.025 +0.015	48	+0.030 +0.018		36		8
60	40		55			41		
66	45		60			46		
76	50		70			51		
86	60	+0.035 +0.020	80	+0.035 +0.020		61		12
96	70		90			71		
110	80		105			81		
120	90		115		91			
135	100		130		101			

注
NOTE

以上只是部分型号，我们可以根据客户的需求进行量身定制。

Note: the above is only part of the model, We could customized according to customer's requirements.

SGBT

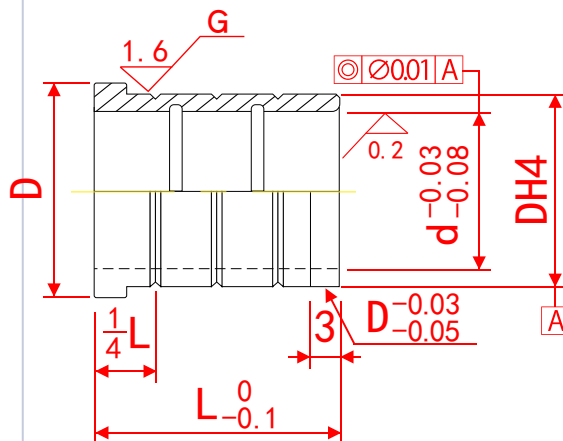

M 材质Material: SUJ2
H 硬度Hardness: 58HRC~

单位Unit:mm

D	DH4		d	L								
15	12	0 -0.005	8	10	13	16	20					
17	14		10	10	13	16	20	22	25			
21	18	0	13		13	16	20	22	25	30		
25	22		16			16	20	22	25	30	35	
28	25	0.006	20			16	20	22	25	30	35	
35	32	0 -0.007	25				20	22	25	30	35	

SGBL

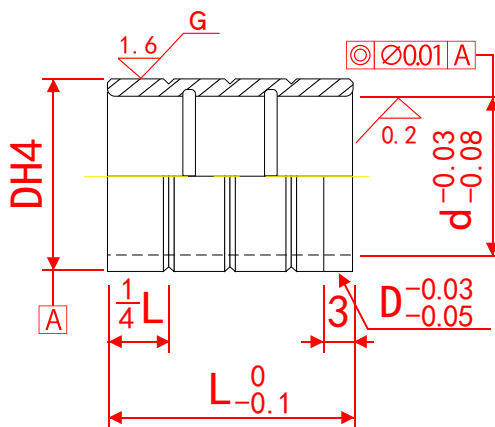

M 材质Material: SUJ2
H 硬度Hardness: 58HRC~

单位Unit:mm

DH4		d	L								
12	0 -0.005	8	10	13	16	20					
14		10	10	13	16	20	22	25			
18	0	13		13	16	20	22	25	30		
22		16			16	20	22	25	30	35	
25	-0.006	20			16	20	22	25	30	35	
32	0 -0.007	25				20	22	25	30	35	

注
NOTE

以上只是部分型号，我们可以根据客户的需求进行量身定制。

Note: the above is only part of the model, We could customized according to customer's requirements.

SGFZ

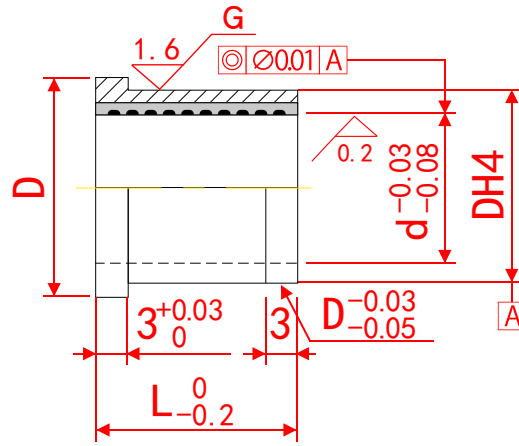

M 材质Material: SUJ2+铜合金Copper Alloy
MOS₂(镶嵌Inlay)

H 硬度Hardness: 45HRC~

单位Unit:mm

D	DH4		d	L									
18	16	0	10	10	13	16	20	22	25				
22	20	-0.005	13		13	16	20	22	25	30			
26	24	0	16			16	20	22	25	30	35		
30	28	-0.006	20			16	20	22	25	30	35		
36	34	-0.007	25				20	22	25	30	35		

SGCZ

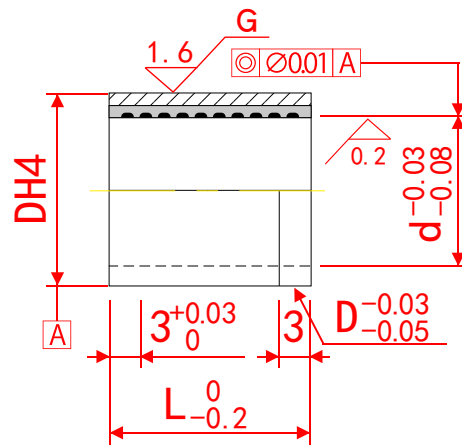

M 材质Material: SUJ2+铜合金Copper Alloy
MOS₂(镶嵌Inlay)

H 硬度Hardness: 45HRC~

单位Unit:mm

DH4		d	L									
16	0	10	10	13	16	20	22	25				
20	-0.005	13		13	16	20	22	25	30			
24	0	16			16	20	22	25	30	35		
28	-0.006	20			16	20	22	25	30	35		
34	0	25				20	22	25	30	35		

注
NOTE

以上只是部分型号，我们可以根据客户的需求进行量身定制。

Note: the above is only part of the model, We could customized according to customer's requirements.

SGBF

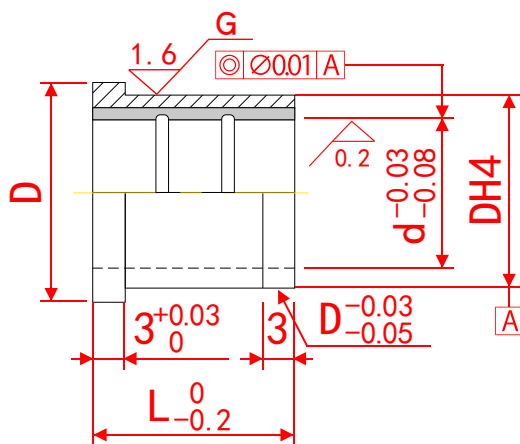

M 材质Material: SUJ2+铜合金Copper Alloy

H 硬度Hardness: 45HRC~

单位Unit:mm

D	DH4		d	L							
18	16	0	10	10	13	16	20	22	25		
22	20	-0.005	13		13	16	20	22	25	30	
26	24	0	16			16	20	22	25	30	35
30	28	-0.006	20			16	20	22	25	30	35
36	34	0	25				20	22	25	30	35

SGSF

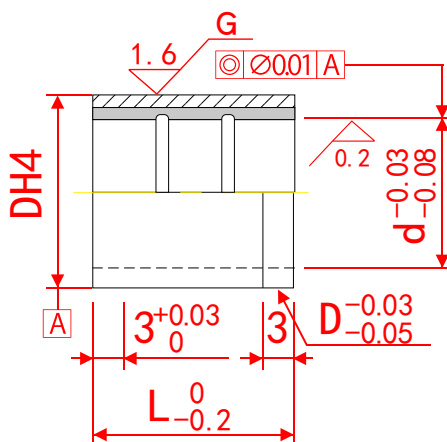

M 材质Material: SUJ2+铜合金Copper Alloy

H 硬度Hardness: 45HRC~

单位Unit:mm

DH4		d	L							
16	0	10	10	13	16	20	22	25		
20	-0.005	13		13	16	20	22	25	30	
24	0	16			16	20	22	25	30	35
28	-0.006	20			16	20	22	25	30	35
34	0	25				20	22	25	30	35

注
NOTE

以上只是部分型号，我们可以根据客户的需求进行量身定制。

Note: the above is only part of the model, We could customized according to customer's requirements.

SGHZ



M材质Material: FC250+MOSz(镶嵌Inlay)

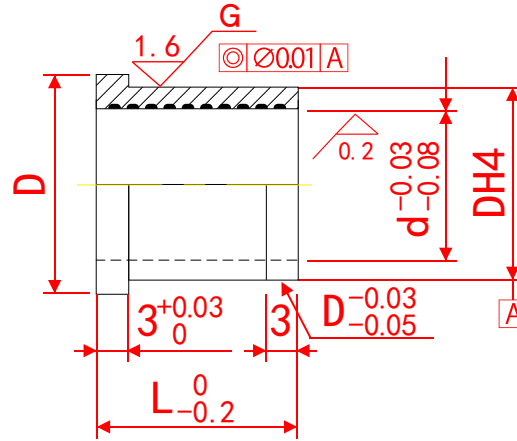

单位Unit:mm

D	DH4		d	L								
15	13	0	8	10	13	16	20					
18	16	-0.005	10	10	13	16	20	22	25			
22	20	0	13		13	16	20	22	25	30		
26	24		-0.006	16			16	20	22	25	30	35
30	28		20			16	20	22	25	30	35	
36	34	-0.007	25				20	22	25	30	35	

SGBZ



M材质Material: FC250+MOSz(镶嵌Inlay)

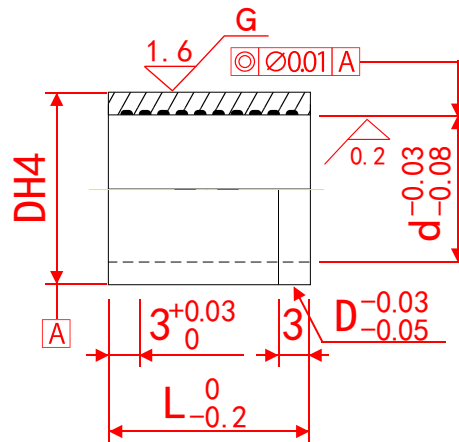

单位Unit:mm

DH4		d	L								
13	0	8	10	13	16	20					
16	-0.005	10	10	13	16	20	22	25			
20	0	13		13	16	20	22	25	30		
24		-0.006	16			16	20	22	25	30	35
28		20			16	20	22	25	30	35	
34	-0.007	25				20	22	25	30	35	

注
NOTE

以上只是部分型号，我们可以根据客户的需求进行量身定制。

Note: the above is only part of the model, We could customized according to customer's requirements.